

Aussie Fit E9500

Recumbent BIKE

OWNER'S MANUAL

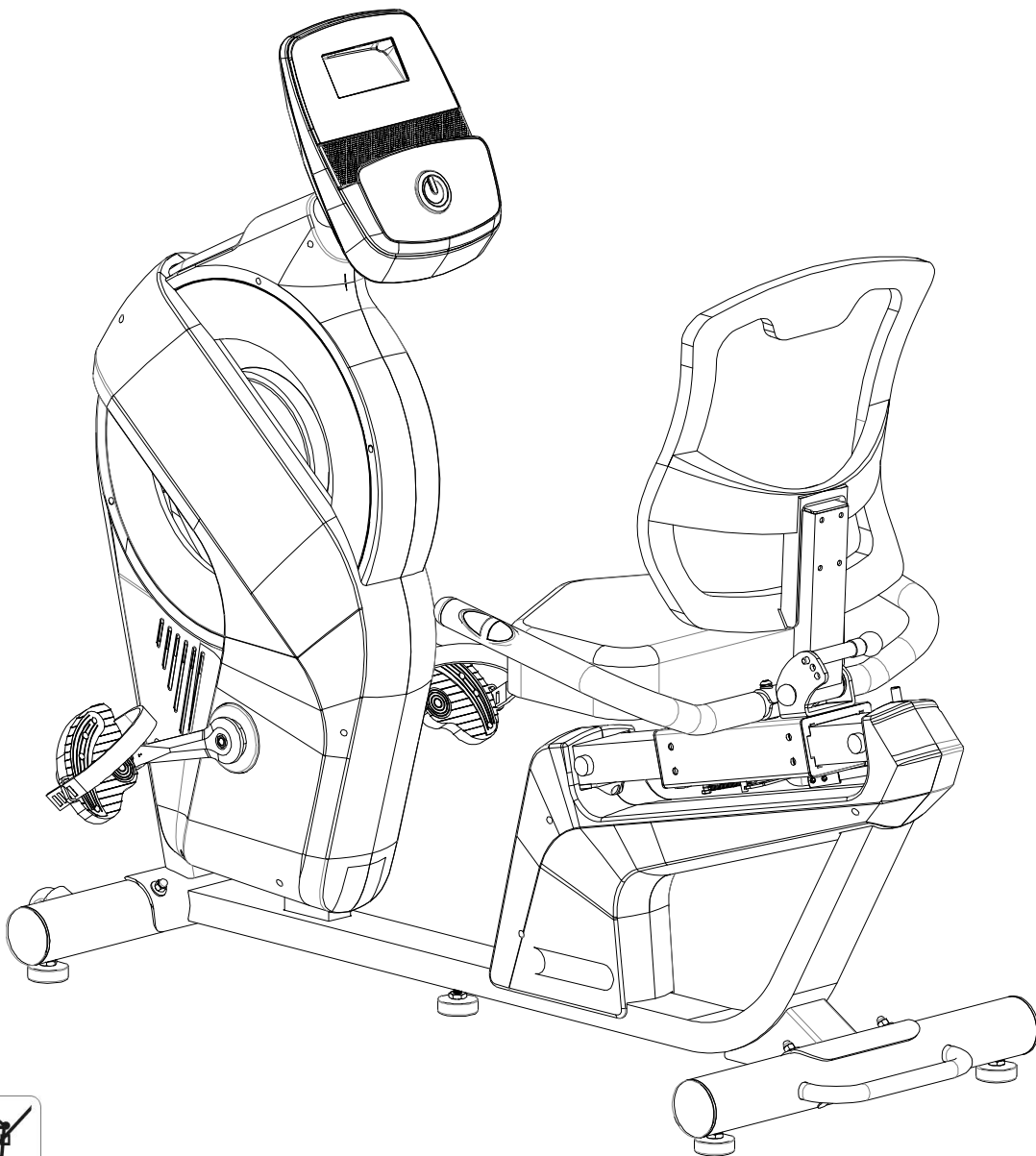

IMPORTANT: Read all instructions carefully before using this product. Retain this

owner's manual for future reference.

The specifications of this product may vary from this photo, subject to change without notice.

SAFETY INSTRUCTIONS

Basic precautions should always be followed, including the following safety instructions when using this equipment: Read all instructions before using this equipment.

1. Read all the instructions in this manual and do warm up exercises before using this equipment.
2. Before exercise, in order to avoid injuring the muscle, warm-up exercise of every position of the body is necessary. Refer to Warm Up and Cool Down Routine page. After exercise, relaxation of the body is suggested for cool-down.
3. Please make sure all parts are not damaged and fixed well before use. This equipment should be placed on a flat surface when using. Using a mat or other covering material on the ground is recommended.
4. Please wear proper clothes and shoes when using this equipment; do not wear clothes that might catch any part of the equipment.
5. Do not attempt any maintenance or adjustments other than those described in this manual. Should any problems arise, discontinue use and consult an *Authorized Service Representative*.
6. Be careful when step on or leave the pedal always hold the handlebars first. Make the pedal at your side at the lowest position, step on the pedal, and stride over the main frame then step on the other pedal. When using, please hold the handlebar by hands, make the pedals running smoothly by push or pull handlebars, then run the equipment regularly by cooperation of hands and feet. After exercise, please also make one pedal at the lowest position and leave your foot on the higher pedal first and then another.
7. Do not use the equipment outdoors.
8. This equipment is for household use only.
9. Only one person should be on the equipment while in use.
10. Keep children and pets away from the equipment while in use. This machine is designed for adults only. The minimum free space required for safe operation is not less than two meters.
11. If you feel any chest pains, nausea, dizziness, or short of breath, you should stop exercising immediately and consult your physician before continuing.
12. The maximum weight capacity for this product is 135kgs.

WARNING: Before beginning any exercise program consult your physician.

This is especially important for the persons who are over 35 years old or who have pre-existing health problems. Read all instructions before using any fitness equipment.

CAUTION: Read all instructions carefully before operating this product.
Retain this Owner's Manual for future reference.

PARTS LIST

No.	Description	Qty	No.	Description	Qty
001	Main Frame	1	031	Eccentric shaft Φ 26x41	1
002	Front Stabilizer	1	032	Skate brake	1
003	Rear Stabilizer	1	033	Crash pad 40.8X28.5X6.1	1
004	Sliding tube assembly	1	034	Brake decorative covers	1
005	Sliding sleeve assembly	1	035	Bolt M5x10	6
006	Back/Seat Support Bracket	1	036	Inside hexagonal Bolt M6x15	2
007	Rear Handlebar	1	037	Outer hexagonal Bolt M6x15	1
008	Brake handle support	1	038	Draw spring	1
009	Brake handle	1	039	Nut M6	1
010	Bolt M8x50	2	040	Bolt M8x20	4
011	Spring washer Φ 8	8	041	Big Washer Φ 8X Φ 20x2.0	4
012	Curve washer Φ 8x Φ 16x2.0	2	042	Crash pad ϕ 25*10-M8*10	4
013	Handlebar Foam Grip Φ 31x Φ 37x520	2	043	Flexible wire L=1700mm	1
014	Circular tube plug Φ 32x1.5	2	044	Plug	1
015	Hand Pulse Sensor with Wire (L=750mm)	2	045	Bolt M8x90	4
016	Bolt ST4.2x20	3	046	Curve washer Φ 8x Φ 20x2.0	4
017	Seat Cushion	1	047	Cap Nut M8	4
018	Back Cushion	1	048	Adjust the foot pad M10	5
019	Bolt M8x45	4	049	Nut M10	5
020	Washer Φ 6	8	050	Circular tube plug Φ 76x2	4
021	Round Knob	1	051	Left Rear Main Frame Cover	1
022	Plastic sleeve Φ 38x Φ 19x20	2	052	Right Rear Main Frame Cover	1
023	Bushing	2	053	Screw ST4.2x20	16
024	Nut cap S13	2	054	Screw ST4.2x25	10
025	Bolt M8x15	2	055	Rubber Sleeve	5
026	Big Washer Φ 8X Φ 25x2.0	2	056	Motor	1
027	Spin axis	1	057	Sensor Extension Wire (L=1100mm)	1
028	Bolt M6x20	4	058	Sensor with Wire (L=450mm)	1
029	Circlip	2	059	Bolt ST2.9x12	2
030	Plastic sleeve Φ 29x9.2	2	060	Limit file piece	4

PARTS LIST

No.	Description	Qty	No.	Description	Qty
061	Bolt M5x15	4	081	Bolt M6x15	4
062	Washer Φ 5	4	082	Belt	1
063	Computer	4	083	Flywheel	1
064	Computer support	1	084	Nut M10x1.0x6	2
065	Left Pedal	1	085	Big Washer Φ 30x10.5	2
066	Right Pedal	1	086	Motor Tension Cable L=500mm	1
067	Cover Cap	2	087	Bolt Φ 8x31	2
068	Nut M10x1.25	2	088	Bearing 608	4
069	Left crank	1	089	Roller	2
070	Right crank	1	090	Bolt M6x12	2
071	Cank Cover	2	091	Power supply wire L=550mm	1
072	Left Chain Cover	1	092	Nut M12	1
073	Right Chain Cover	1	093	AC Adapter wire L=2000mm	1
074	Circlip Φ 20	2			
075	Wave spring washer	1			
076	Bearing	2			
077	Nut M6	4			
078	Spring Washer Φ 8	4			
079	Belt Pulley with Crank	1			
080	Straight spindle assembly	1			

HARDWARE PACKING LIST

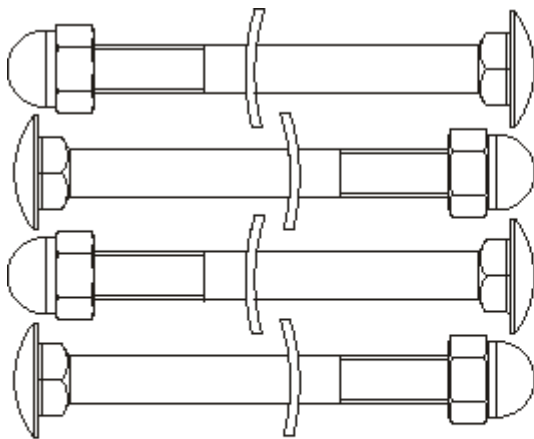

#45 Bolt M8x90 4PCS
 #46 Curve Washer $\phi 8 \times \phi 20$ 4PCS
 #47 Cap Nut M8 4PCS

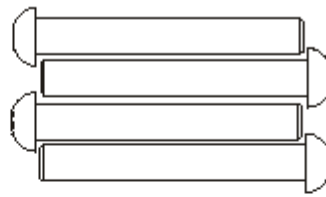

#19 Bolt M6x45 4PCS

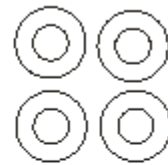

#20 Washer $\phi 6 \times \phi 12$ 4PCS

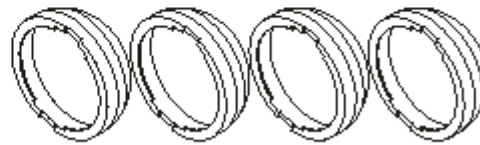

#24 Cap Nut S13 4PCS

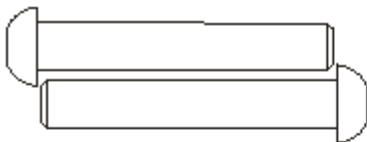

#10 Bolt M8x50 2PCS



#11 Spring Washer $\phi 8$ 2PCS



#12 Washer $\phi 8 \times \phi 16$ 2PCS

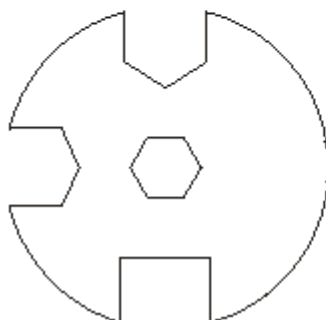

Allen Wrench S6 1pc

Allen Wrench S5 1pc

Multi Hex Tool with Phillips Screwdriver
 S10-13-14-15 1PC

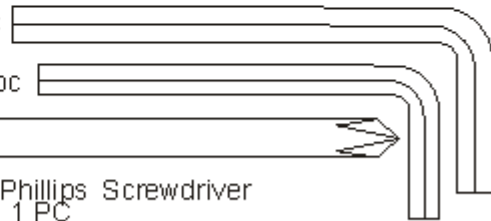

OVERVIEW DRAWING

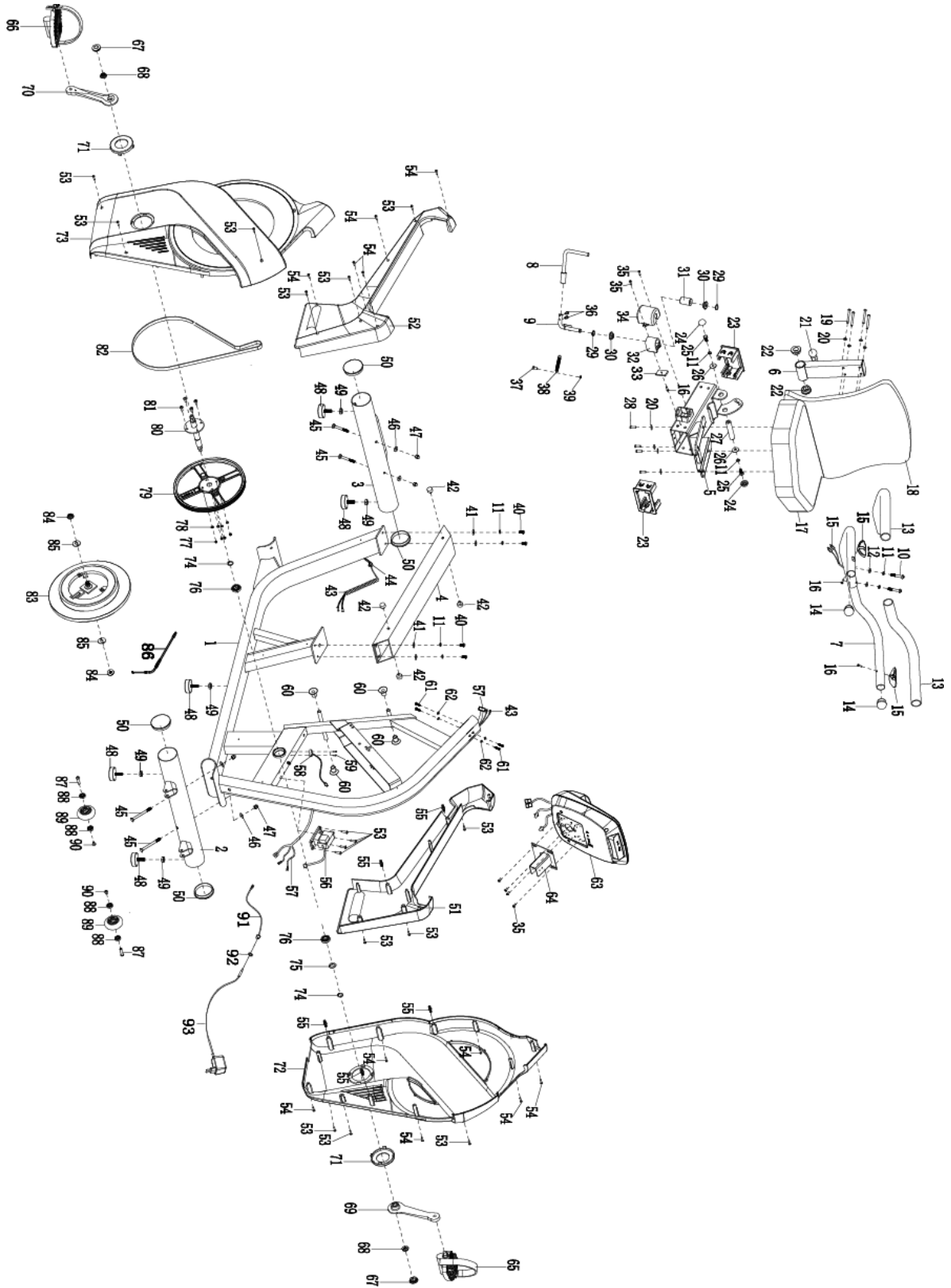

ASSEMBLY INSTRUCTIONS

1. Front and Rear Stabilizer Installation

A. Position two Foot Pad(48) onto the Front Stabilizer (2)

B. Position two Foot Pad(48) onto the Rear Stabilizer (3)

C. Position the Front Stabilizer (2) in front of Main Frame (1) and align bolt holes. Attach the Front Stabilizer (2) onto the front curve of the Main Frame (1) with two M8x90 Bolts (45), Ø8xØ20x2.0 Curve Washers (46) and M8 Cap Nut (47).

D. Position the Rear Stabilizer (3) in front of Main Frame (1) and align bolt holes. Attach the Rear Stabilizer (3) onto the front curve of the Main Frame (1) with two M8x90 Bolts (45), Ø8xØ20x2.0 Curve Washers (46) and M8 Cap Nut (47).

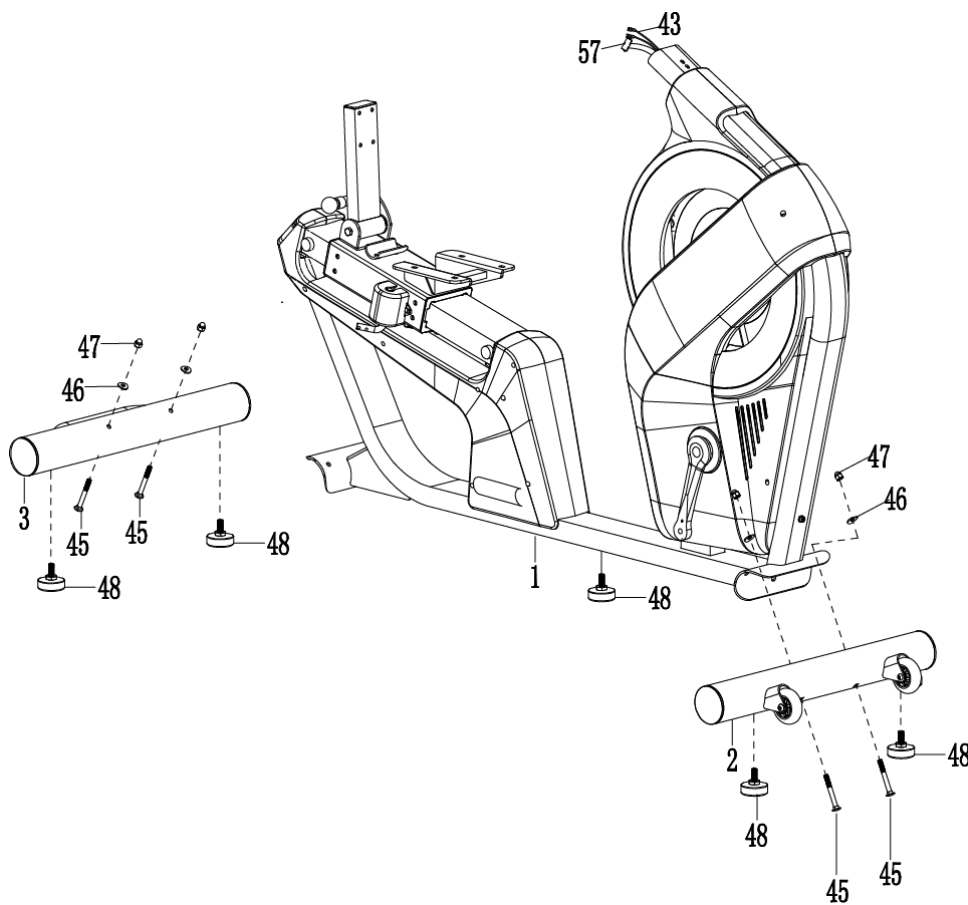

2. Pedal and brake handle Installation

Important:

Make sure the RIGHT pedal matches up with the RIGHT crank and the LEFT pedal matches up with the LEFT crank. If reversed the cranks may become damaged or stripped.

- A. Left Pedal Installation:** Insert the Left Pedal(65) into the threaded hold in the Left Crank(69). Turn the pedal shaft by hand in a counter-clockwise direction and tighten using the multi Hex Tool with Phillips Screwdriver.
- B. Right Pedal Installation:** Insert the Right Pedal(66) into the threaded hold in the Left Crank(70). Turn the pedal shaft by hand in a counter-clockwise direction and tighten using the multi Hex Tool with Phillips Screwdriver.
- C.** Remove two M6x15Bolts(36)from the brake handle support(9),attach the brake handle(8) onto the brake handle support(9) with M6x15Bolts(36) that were removed.
- D.** Attached two S13 Cap Nut (24) onto the Back/Seat Support Bracket(6) Left and Right.

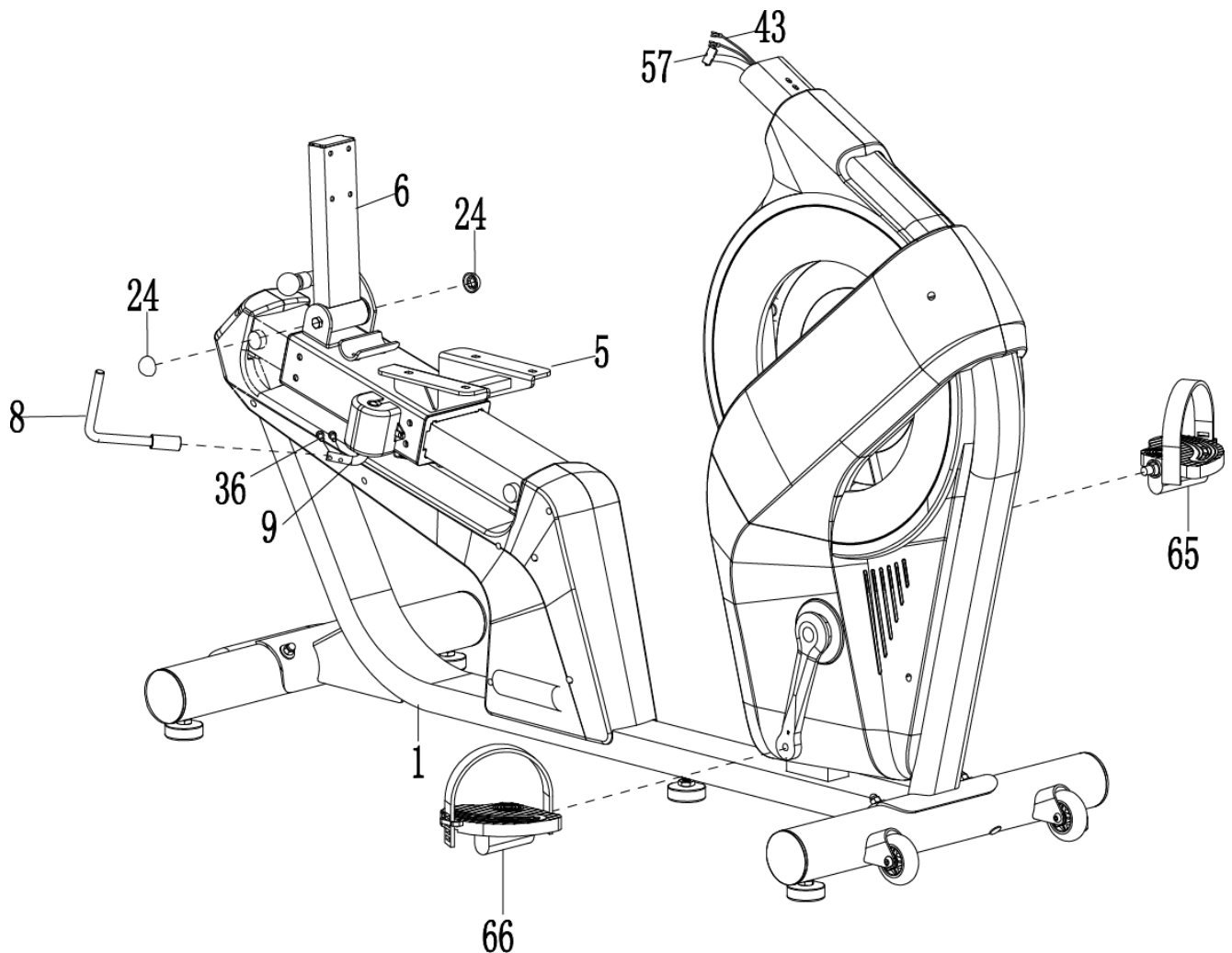

3. Seat Cushion Installation

Remove four Bolt M6x20(28) and four Flat Washer Φ 6(20) from Seat Cushion (17).

Then attach the Seat Cushion (17) onto the Seat Support Bracket (5) with four Bolt M6x20(28) and four Flat Washer Φ 6(20) that were removed.

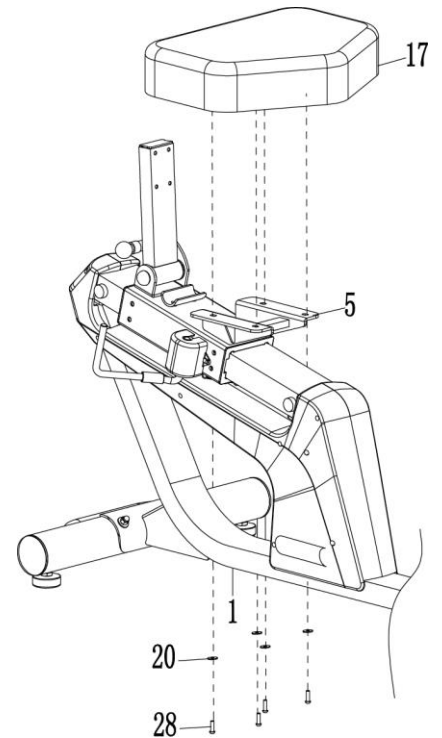

4. Back Cushion Installation

Remove four Bolt M6x45(19) and four Flat Washer Φ 6(20) from Back Cushion (18). Then attach the Back Cushion (31) onto the Back Support Bracket (6) with Bolt M6x45(19) and four Flat Washer Φ 6(20) that were removed.

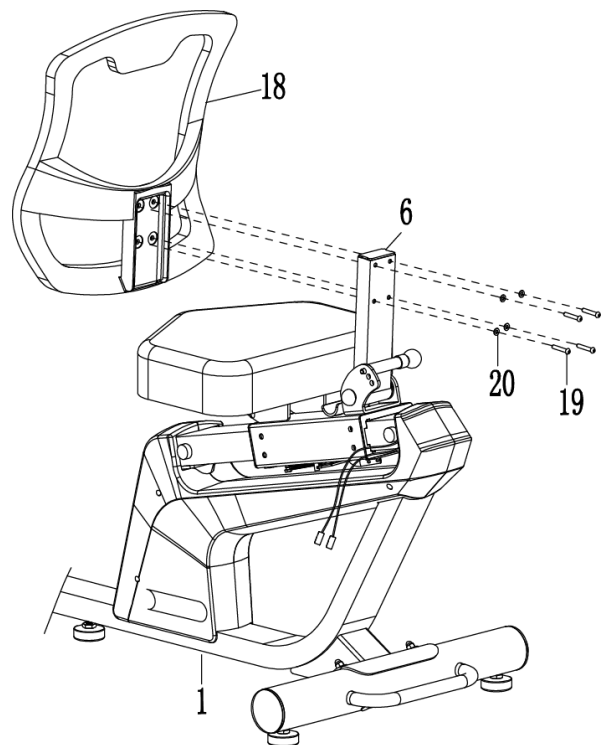

5. Handlebar Installation

Attach the Rear Handlebar (7) onto the Seat Support Bracket (5) with two M8x50mm Bolts (10), two Ø8 Spring Washers (11) and two Ø8xØ16x2.0 Curve Washers (12).

Connect the Flexible wire (43) from the Main Frame (1) to the Hand Pulse Sensor Wires (15) from the Rear Handlebar (7).

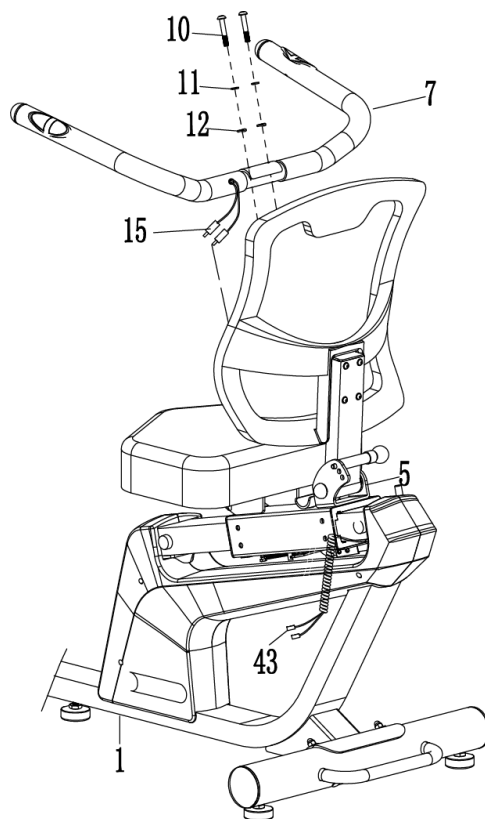

6. Computer Installation

A. Remove four Screw M5x10(35) from computer (63). Attach the Computer (63) onto the Computer support (64) with four Screw M5x10(35) that were removed.

B. Remove four screw M5x15(61) and four washer washer Ø5 (62) from the Computer support (64). Connect Flexible wire (43) and Sensor Extension Wire (57) from the Main Frame (1) to the wires that come from the Computer (63) and then attach the Computer (63) onto the top end of the Main Frame (1) with four screw M5x15(61) and four washer washer Ø5 (62) that were removed.

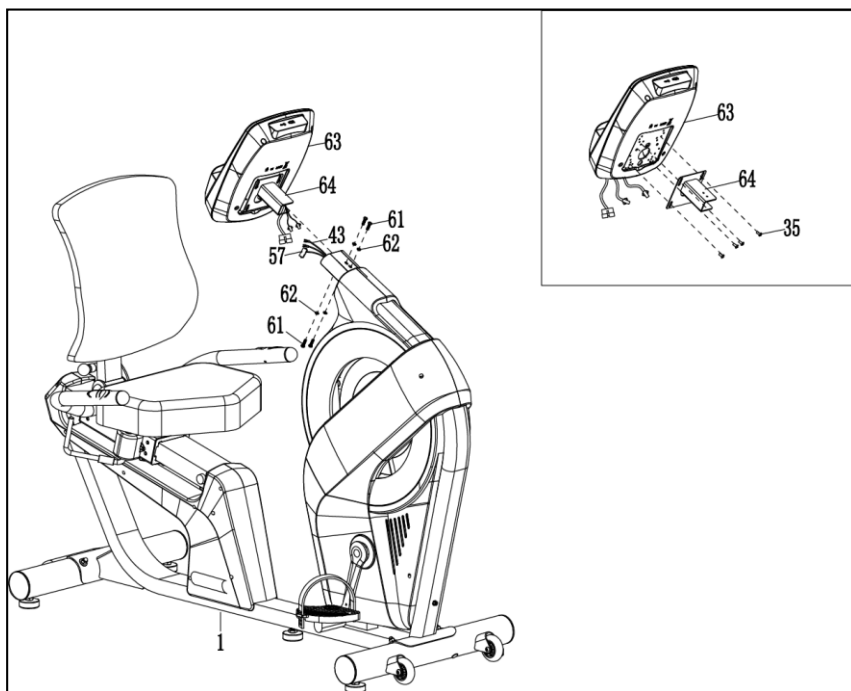

7. AC Adapter Installation

Plug one end of the AC Adapter(93) into the power jack of the Power Supply Wire(91) on the Front of the Right Chain Cover. Before plugging in,make sure to check carefully the specifications on the Adapter. Plug the other end of the AC Adapter(93) into the electrical wall outlet.

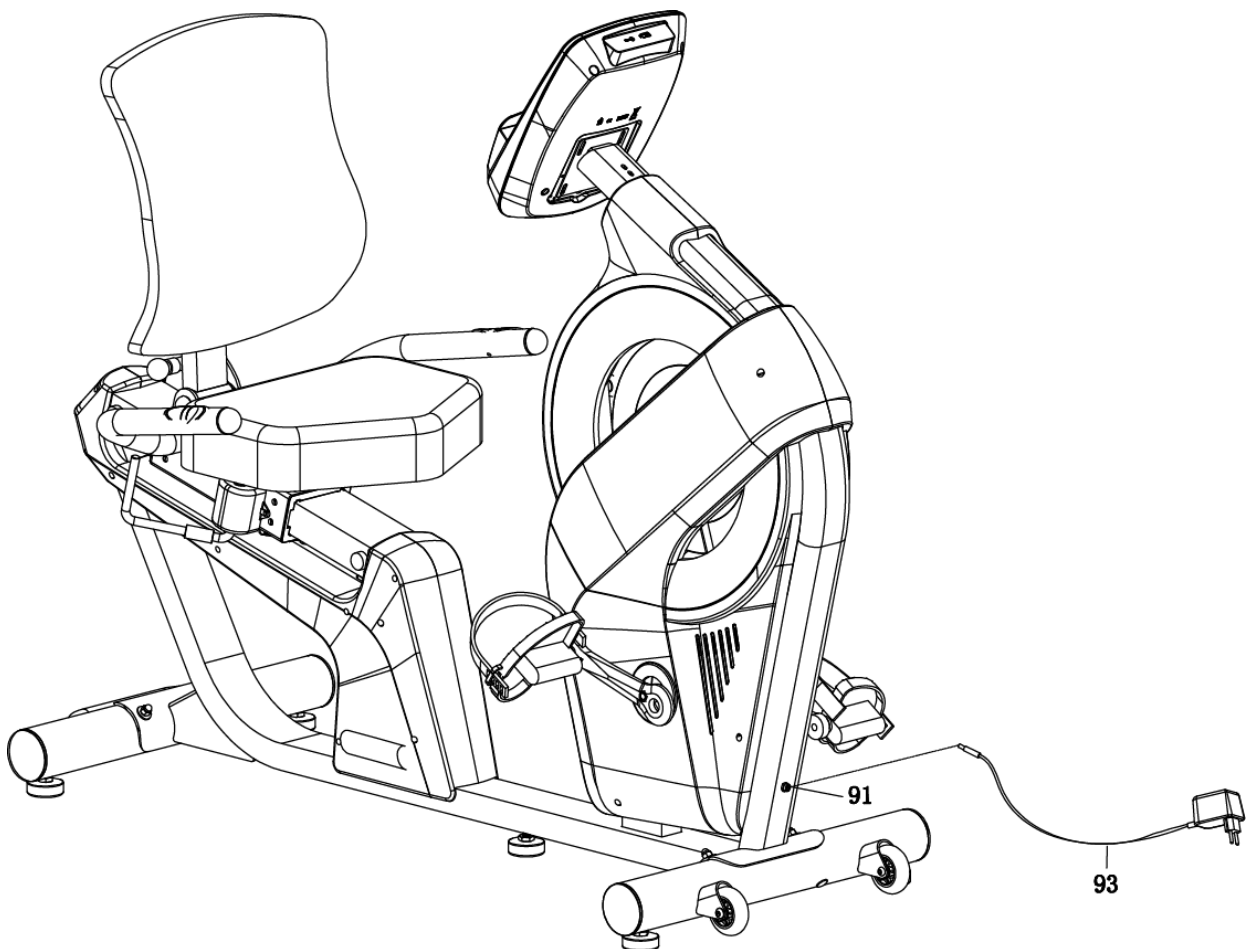

Instruction Manual

KEY FUNCTION:

START/STOP -Start or Stop workout.

RESET

- In STOP mode, press this key to go back to main menu;
- Hold on pressing for 2 seconds, computer will reboot and start from user setting.

UP (+)

- Increase resistance level.
- Setting selection.

MODE/ENTER

- In STOP mode, press it to confirm all setting or selection and enter program.

DOWN (-)

- Decrease resistance level.
- Setting selection.

RECOVERY

- Test heart rate recovery status.

BODY FAT

- Body Fat% measurement.

DISPLAY RANGE:

TIME

Display range 0:00 ~ 99:99; setting range 0:00 ~ 99:00 minutes

DISTANCE

Display range 0 ~ 99.99; setting range 0 ~ 99.90KM

CALORIES

Display range 0 ~ 9999; setting range 0 ~ 9990Cal.

PULSE

Display range P-30 ~ 230; setting range 0-30 ~ 230

WATT

Display range 0 ~ 999; setting range 10 ~ 350

SPEED 0.0~99.9KM/H

RPM 0~999 revolutions

OPERATION PROCEDURE:

1. Plug in power supply (or press RESET KEY for 2S), BUZZER will sound one beep for 1 second.

And LCD full display 2 seconds (Drawing 1) then display wheel diameter and KM or ML (Drawing 2). Then console come to Standby mode (Drawing 3).

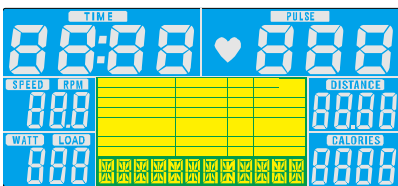

Drawing 1



Drawing 2

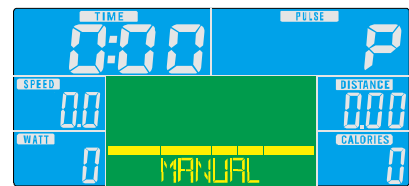

Drawing 3

2. Select workout program in sequence: MANUAL→BEGINNER→ADVANCE→SPORTY→CARDIO→WATT.

3. If user select “MANUAL” and press MODE key, enter to TIME setting. Press UP (+) /DOWN

(-) to select target time (Drawing 4) and confirm by MODE. Then set DISTANCE/CALORIES/

PULSE (Drawing 5~8). After setting, press START/STOP to start workout, Console will start to calculate values. Press UP (+) /DOWN (-) to adjust LOAD level



Drawing 4



Drawing 5



Drawing 6



Drawing 7



Drawing 8

4. If user want to select BEGINNER mode (Drawing 9), press START/STOP no matter in any mode, then press RESET go to main menu. When MANUAL is flashing, press UP (+) once and MODE key to enter BEGINNER mode (Drawing 10). Press UP (+) /DOWN (-) to select ADVANCE 1~4 and confirm by MODE. Set target TIME with UP (+) /DOWN (-) or start workout directly. During workout, user can press UP (+) /DOWN (-) to adjust LOAD level.

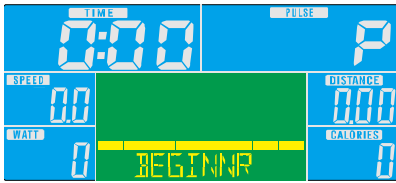

Drawing 9

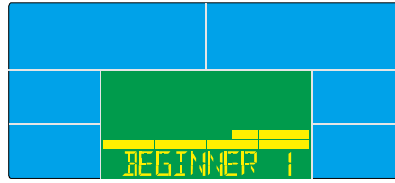

Drawing 10

5. If user want to select ADVANCE mode(Drawing11),press START/STOP no matter in any mode, then press RESET go to main menu. When MANUAL is flashing, press UP (+) twice and MODE key to enter ADVANCE mode (Drawing12). Press UP (+) /DOWN (-) to select ADVANCE 1~4 and confirm by MODE. Set target TIME with UP (+) /DOWN (-) or start workout directly. During workout, user can press UP (+) /DOWN (-) to adjust LOAD level.



Drawing 11

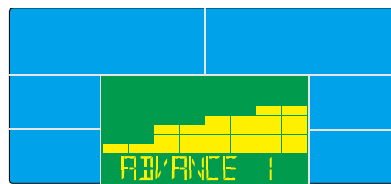

Drawing 12

6. If user want to select SPORTY mode (Drawing 13),press START/STOP no matter in any mode, then press RESET go to main menu. When MANUAL is flashing, press UP (+) 3 times and MODE key to enter SPORTY mode (Drawing 14). Press UP (+) /DOWN (-) to select SPORTY 1~4 and confirm by MODE. Set target TIME with UP (+) /DOWN (-) or start workout directly. During workout, user can press UP (+) /DOWN (-) to adjust LOAD level.

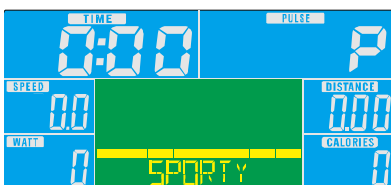

Drawing 13



Drawing 14

7. If user want to select CARDIO mode (Drawing 15), press START/STOP no matter in any mode, then press RESET go to main menu. When MANUAL is flashing, press UP (+) 4 times and MODE key to enter CARDIO mode. Press UP (+) /DOWN (-) to set user AGE (Drawing 16), then press MODE to go to different CARDIO program selection. Press UP (+) /DOWN (-) to select CARDIO 55%,CARDIO 75%,CARDIO 90%,CARDIO TAG (Drawing 17). Set target TIME with UP (+) /DOWN (-) or start workout directly. If no pulse input to computer after starting workout for 6s, LCD will display "PULSE INPUT" for reminder (Drawing 18).

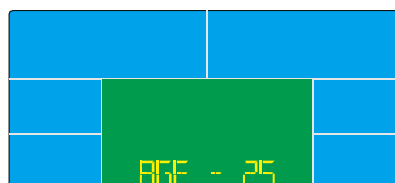

Drawing 15

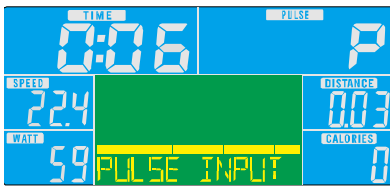

Drawing 16

Drawing 17

Drawing 18

8. If user want to select WATT mode (Drawing 19),press START/STOP no matter in any mode, then press RESET go to main menu. When MANUAL is flashing, press UP (+) 5 times and MODE key to enter WATT mode. Press UP(+)/DOWN(-)to set target WATT with range of 10~350, preset value is 120 (Drawing 20). Then press MODE to go to TIME setting (from 1~99 minutes) or press START/STOP to start workout directly. During workout, system will adjust load level according to input value and workout status (Drawing 21). Press UP (+) /DOWN (-) to set WATT value.

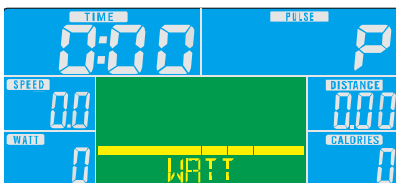

Drawing 19



Drawing 20

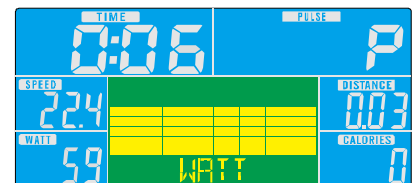

Drawing 21

9. RECOVERY mode

After exercising for a period of time, keep holding on hand grips and press “RECOVERY” Button. All function display will stop except “TIME” starts counting down from 00:60 to 00:00 (Drawing 22). Screen will display your heart rate recovery status with the F1, F2...to F6 (Drawing 23). F1 is the best, F6 is the worst.

(Press the RECOVERY button again to return the main display.)

User may keep exercising to improve the heart rate recovery status.

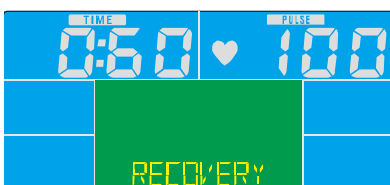

Drawing 22



Drawing 23

10. BODY FAT measurement

In STOP mode, press the BODY FAT button to start body fat measurement.

Then press UP (+)/DOWN (-) to set user profile (Drawing 24~26). After setting, system start measuring. During measuring, user have to hold both hands on the hand grip. And the LCD will display “--” “-- “for 8 seconds (Drawing 27) until computer finish measuring. When finish measuring, LCD will display BODY FAT advice symbol, BODY FAT percentage (Drawing 28),BMI (Drawing 29) for 30 seconds.

During personal profile setting, user may press RESET to correct setting.

Press BODY FAT button again to go back to previous workout status.

※ Error code display during measurement:

E-1--- user not hold hand grips correctly (Drawing 30)

E-4--- Body Fat% exceed setting range (5.0%~ 50%, Drawing 31)



Drawing 24



Drawing 25



Drawing 26

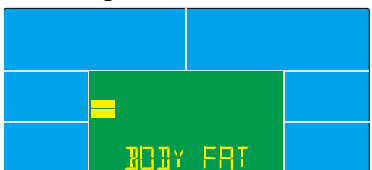

Drawing 27



Drawing 28

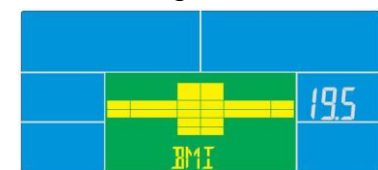

Drawing 29

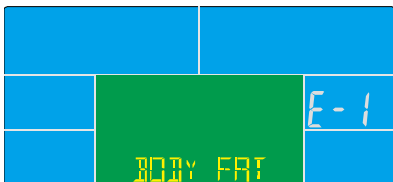

Drawing 30

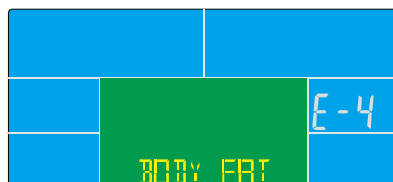

Drawing 31

System reminder:

※This console has the bell prompt function on button:

- ①effective operation- one short beep;
- ②ineffective operation- two short beeps;
- ③any function value count down to 0 during workout- 4 short beeps every second
- ④In H.R.C. & WATT CONTROL mode, when console is forced to stop- continuous 6 short beeps
- ⑤When PULSE exceed setting value- 2 short beeps every second
- ⑥When WATT exceed setting value- 3 short beeps every second

MP3 Function:

User can connect mobile or music player to console with an audio cable for MP3 function. Then click the player, console will play music.

(Reminder: console only has the function of power amplifier but not read memory card.)

USB power charger:

The console can provide USB charger for tablet or smart phone. User just plug the data cable into USB port for charging.

SM2526-67 Instruction Manual

APP function:

The console has been built-in Bluetooth for APP function. Download i-Console+ APP to tablet

first, then pair tablet and console thru BT.

(APP operation refer to i-Console+ Instruction Manual)

Remark:

This console has function of MP3/USB charger/BT), thus consume much power. For stable workout and function stability, we suggest user to use adaptor of 9V 1.3A or above.

MAINTENANCE

Cleaning

The recumbent bike can be cleaned with a soft cloth and mild detergent. Do not use abrasives or solvents on plastic parts. Please wipe your perspiration off the recumbent bike after each use. Be careful not get excessive moisture on the computer display panel as this might cause an electrical hazard or electronics to fail.

Please keep the recumbent bike, specially, the computer console, out of direct sunlight to prevent screen damage.

Please inspect all assembly bolts and pedals on the machine for proper tightness every week.

Storage

Store the recumbent bike in a clean and dry environment away from children.

TROUBLESHOOTING

WARM UP AND COOL DOWN ROUTINE

A good exercise program consists of a warm-up, aerobic exercise, and a cool down. Do the entire program at least two to three times a week, resting for a day between workouts. After several months you can increase your workouts to four or five times per week.

AEROBIC EXERCISE is any sustained activity that sends oxygen to your muscles via your heart and lungs. Aerobic exercise improves the fitness of your lungs and heart. Aerobic fitness is promoted by any activity that uses your large muscles eg: legs, arms and buttocks. Your heart beats quickly and you breathe deeply. An aerobic exercise should be part of your entire exercise routine.

The **WARM-UP** is an important part of any workout. It should begin every session to prepare your body for more strenuous exercise by heating up and stretching your muscles, increasing your circulation and pulse rate, and delivering more oxygen to your muscles.

COOL DOWN at the end of your workout, repeat these exercises to reduce soreness in tired

PROBLEM	SOLUTION
The recumbent bike wobbles when in use.	Turn the adjustable leveler on the rear stabilizer as needed to level the recumbent bike.
There is no display on the computer console.	<ol style="list-style-type: none"> 1. Remove the computer console and verify the wires that come from the computer console are properly connected to the wires that come from the front post. 2. Check if the batteries are correctly positioned and battery springs are in proper contact with batteries. 3. The batteries in the computer console may be dead. Change to new batteries.
There is no heart rate reading or heart rate reading or is erratic / inconsistent.	<ol style="list-style-type: none"> 1. Make sure that the wire connections for the hand pulse sensors are secure. 2. To ensure the pulse readout is more precise, please always hold on to the handlebar grip sensors with two hands instead of just with one hand only when you try to test your heart rate figures. 3. Gripping the hand pulse sensors too tight. Try to maintain moderate pressure while holding onto the hand pulse sensors.
The recumbent bike makes a squeaking noise when in use.	The bolts may be loose on the recumbent bike, please inspect the bolts and tighten the loose bolts.

muscles.

HEAD ROLLS

Rotate your head to the right for one count, feeling the stretch up the left side of your neck, then rotate your head back for one count, stretching your chin to the ceiling and letting your mouth open. Rotate your head to the left for one count, then drop your head to your chest for one count.

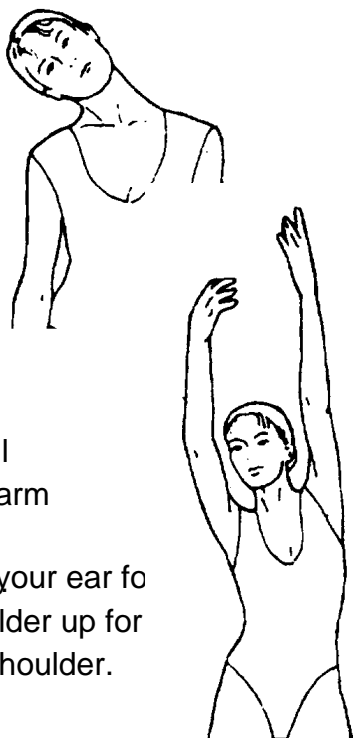

SIDE STRETCHES

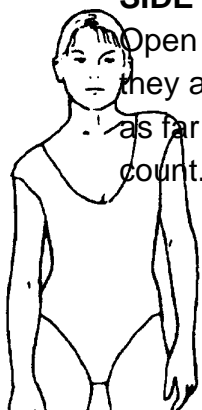

Open your arms to the side and lift them until they are over your head. Reach your right arm as far toward the ceiling as you can for one count. Repeat with your left shoulder toward the ceiling. Lift your right shoulder toward your ear for one count. Then lift your left shoulder up for one count as you lower your right shoulder.

SHOULDER LIFTS

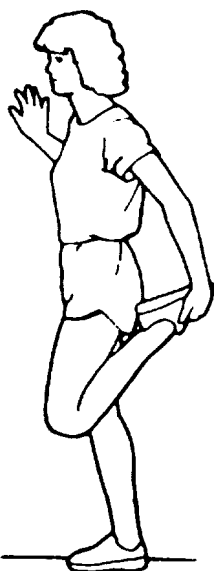

QUADRICEPS STRETCH

With one hand against a wall for balance, reach behind you and pull your right foot up. Bring your heel as close to your buttocks as possible. Hold for 15 counts and repeat with left foot.

INNER THIGH STRETCH

Sit with the soles of your feet together and your knees pointing outward. Pull your feet as close to your groin as possible. Gently push your knees toward the floor. Hold for 15 counts.



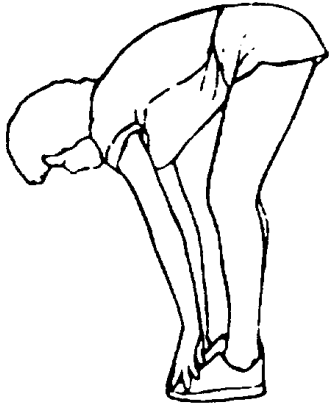

TOE TOUCHES

Slowly bend forward from your waist, letting your back and shoulders relax as you stretch toward your toes. Reach as far as you can and hold for 15 counts.

HAMSTRING STRETCHES

Extend your right leg. Rest the sole of your left foot against your right inner thigh. Stretch toward your toe as far as possible. Hold for 15 counts. Relax and then repeat with left leg.

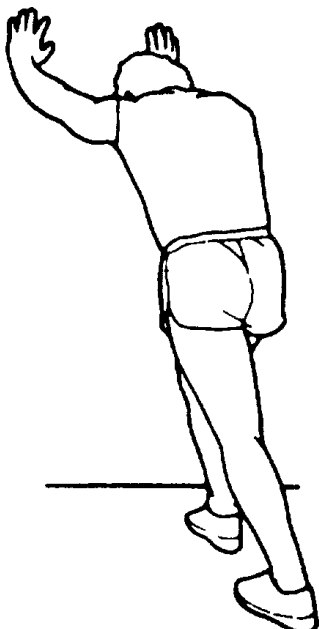
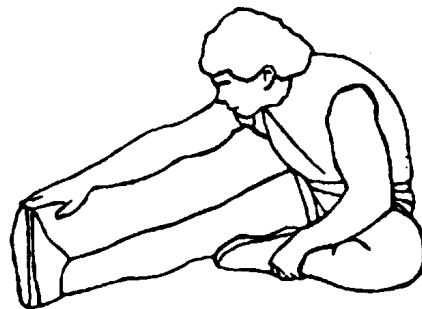

CALF/ACHILLES STRETCH

Lean against a wall with your left leg in front of the right and your arms forward. Keep your right leg straight and the left foot on the floor; then bend the left leg and lean forward by moving your hips toward the wall. Hold, then repeat on the other side for 15 counts.

Keep Fit Hire

1300 800 776

www.keepfithire.com